



## ZP7-IB

Sensor base isolator

### Common to all ZP7 sensors

ZP7P-IB common isolator base, allows any ZP700 analogue sensor to be removed or replaced without disconnecting loop wiring from sensor terminals. Sensors plug into the base unit with a simple twist and lock action, allowing quick and easy removal for cleaning and servicing, or reselection of device type should the usage of the protected area change. Designed to provide short circuit protection for loop wiring, isolators divide the loop into monitored sections. A total of 11 isolator units (sensor base and stand alone) can be connected along each ZP loop, which together with isolators at the beginning and end (internal to the panel), enable each loop to be divided into a maximum of 12 monitored sections. Where the performance specification of the ZP3 panel is not to EN54, the number of isolators on each loop can be increased to 16.



### Open and short circuit protection

The ZP7-IB is intended for use on a "Class-A" return loop wiring configuration. A single zone, or up to 20 detectors or devices (some standards permit up to 32) is located between each pair of loop isolators. In the event of a short circuit fault the isolators on either side of the fault will disconnect the section of cable between them. Devices outside the disconnected section will continue to operate normally.

In the event of an open circuit fault on the loop wiring, the control panel operates from both ends, running the line as two spurs and retaining full connection to all devices.

Meeting the recommendations for system monitoring in most local codes (e.g. BS 5839 Part1), the ZP7-IB isolator base can be used in conjunction with the ZP760 stand alone isolator to provide short circuit fault protection across all loop configurations.

### Locking base option

Adding isolator bases has no affect on loop addressing – sensors are individually identified in the normal way by the control panel, with a maximum of 127 line devices on each loop. An optional lock is provided to lock the sensor into the base, preventing removal without a special tool. Situated on the base moulding, an amber LED indicator flashes when the unit is in operation.

### Standard Features

- Provides short circuit loop protection
- LED indication of loop section isolated
- Optional base lock
- Meets the recommendations of most local codes (e.g. BS 5839 Pt1)
- Compatible with stand alone isolators

# ZP7-IB

## Sensor base isolator

### Specifications

Model No	ZP7-IB
Specification	EN54
Description	Sensor isolator base
Compatibility	All ZP analogue systems
Mounting	Surface
Wiring	2 core "Class-A" return loop. Total loop = 75 ohms maximum. Between isolators = 18 ohms maximum. See ZP wiring guide GA 322
Monitoring	Unit monitors loop wiring for short circuit faults
Addressing method	Soft addressed by panel software (does not require an address number)
Indication	LED (amber)
Operating voltage	Loop 19.5-20.5 Vdc
Current	600uA quiescent, 800uA fault
Application	Indoor installation
EN60529 rating	IP21
Temperature range	-10°C to +55°C
Humidity range (at 40oC)	10% to 95% RH (non condensing)
EMC	CPD compliant
Material	Moulded thermoplastic
Dimensions	109mm (Dia) x 23mm (H)
Colour	White
Weight	87g
Publication No	PS2017

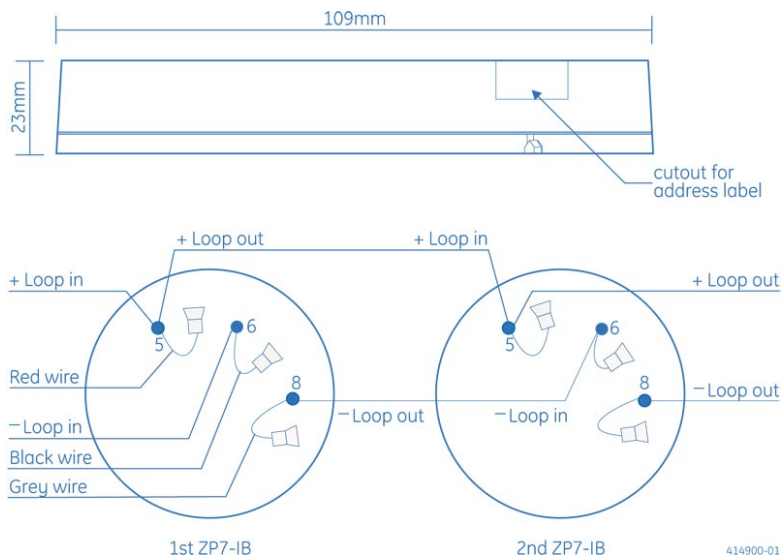

### Ordering Information

Part No.	Description
ZP7-IB	Sensor base isolator

As a company of innovation, GE Security reserves the right to change product specifications without notice. For the latest product specifications, visit GE Security online or contact your GE Security sales representative.

IPS-ZP7-IB-2007-07-31 11:01:34 Released : 12.07.2007

UK Sales: 8 Newmarket Court, Chippenham Drive, Kingston, Milton Keynes, MK10 0AQ, United Kingdom, Telephone +44 (0) 1908 281981, Fax +44 (0) 1908 282554  
 South Africa: Zitton House, 555 Voortrekker Road, Maitland, 7405, P.O. Box 181, Maitland, 7404, South Africa, Telephone +27 (0)21 506 6000, Fax +27 (0)21 506 6050